



Figure 1. Physical photo of TEC5V6A-D

FEATURES

- High Efficiency: $\geq 90\%$
- Maximum Output Current: 6A
- Maximum Output Voltage: $V_{VPS} - 0.3V$
- Actual Object Temperature Monitoring
- High Stability: $0.01^\circ C$
- High Reliability
- Zero EMI
- Compact Size
- 100 % lead (Pb)-free and RoHS compliant

DESCRIPTION

The TEC5V6A-D is an electronic module designed for driving TECs (Thermo-Electric Coolers) with high stability in regulating the object temperature, high energy efficiency, zero EMI, and small package. Figure 1 is the photo of the actual TEC5V6A-D.

This module provides interface ports for users to set the desired object temperature, i.e. set-point temperature; the maximum output voltage across TEC; and the compensation network. The compensation network compensates the high order thermal load and thus stabilizes the temperature control loop.

It provides these functions: thermistor T-R curve linearization, temperature measurement and monitoring, temperature control loop status indication, TEC voltage monitoring, power up delay, and shut down.

The TEC5V6A-D comes with a high stability low noise 3.0V voltage reference which can be used for setting the desired object temperature by using a POT (Potentiometer) or a DAC (Digital to Analog Converter). When using this reference for setting the set-point temperature, the set-point temperature error is independent of this reference voltage. This is because the internal temperature measurement network also uses this voltage as the reference, the errors in setting the temperature and measuring the temperature cancel with each other, setting the object temperature with higher stability. This reference can also be utilized by an ADC (Analog to Digital Converter), for the same reason, the measurement error will also be independent of the reference voltage, resulting in a more accurate measurement.

Figure 2 is the real size top view of the controller showing the pin names and locations with the actual size. TEC5V6A-D pin functions are shown in Table 1.

Warning: This controller module can only be soldered manually on the board by a solder iron of $< 310^\circ C$ ($590^\circ F$), it cannot go through a reflow oven process.

We have two versions for this TEC controller, TEC5V6A-D and TEC5V6A-DA:

For **TEC5V6A-D**, TEMP=Off @SDNG=0

For **TEC5V6A-DA**, TEMP=On @SDNG=0

The TEC5V6A-D is packaged in a 6 sided metal enclosure, which blocks EMIs (Electro-Magnetic Interferences) to prevent the controller and other electronics from interfering with each other.

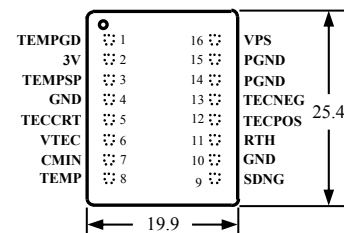

Figure 2. Pin names and locations

SPECIFICATIONS

Table 1 Pin Function Descriptions

Pin #	Pin Name	Type	Description
1	TEMPGD	Digital output	Temperature good indication. It is pulled high when the set-point temperature and the actual desired object temperature are $<0.1^{\circ}\text{C}$ in temperature difference when the set-point temperature range is 20°C ; or $<3\text{mV}$ in voltage difference between the voltages of TEMP and TEMPSP nodes. On this pin, there is an internal pull up resistor of 10k tied to the VPS rail. When going low, this pin is pulled down by an open drain FET with a resistance of $250\Omega @ V_{\text{VPS}} = 5\text{V}$. *A 100nF capacitor to GND needs to be added to this TEC controller manufactured before March 27 th , 2012. Otherwise, there will be an interference of $V_{\text{p-p}}=200\text{mV}$, $f=500\text{kHz}$.
2	3VR	Analog output	Reference voltage output, 3V. It can be used by a POT or DAC for setting the set-point temperature voltage on the TEMPSP pin and/or a DAC for measuring the temperature through the TEMP pin. The maximum sourcing current capability is 1.5mA and the maximum sinking is 4mA with a stability of $<50\text{ppm}/^{\circ}\text{C}$ max.
3	TEMPSP	Analog input	Object set-point temperature input port. It is internally tied by a 500k resistor to the half value of the reference voltage, 1.5V. The open circuit voltage of this pin is thus 1.5V, corresponding to a set-point temperature of 25°C by using the default temperature network (with the set-point temperature range being from 15°C to 35°C). It is highly recommended to set this pin's voltage by using the controller's voltage reference. The lower limit of the setting voltage for this pin is 0.1V. Setting this pin to a $<0.1\text{V}$ voltage may cause the controller over cooling the object. This pin can also be set to a voltage that is about 0.2V away from the VPS rail. For example, when $V_{\text{VPS}} = 5\text{V}$, this pin can be set up to 4.8V, corresponding to approximately 50°C in temperature when the default temperature network is in place, see the curve shown in Figure 8. This pin can be set by using a POT or DAC. When the set-point temperature needs to be at 25°C , leave this pin unconnected.
4	GND	Ground	Signal ground for the POT, ADC, DAC and the thermistor, see Figure 4.
5	TECCRT	Both analog input and output	TEC control voltage. It can be left unconnected or used to control the TEC voltage directly. Set TECCRT between 0V to VPS, the voltage across TEC will be: TEC voltage = $V_{\text{VPS}} - 2 \times V_{\text{TECCRT}}$. It can also be used to configure the maximum voltage across the TEC: Max. TEC voltage = $V_{\text{VPS}} \times R_{\text{m}} / (R_{\text{m}} + 10\text{k})$, where R_{m} is the resistance of the two resistors one between TECCRT to GND and the other between TECCRT to VPS, see Figure 4.
6	VTEC	Analog output	TEC voltage indication. TEC voltage = $[\text{max. TEC voltage}] \times [V_{\text{VPS}} - 2 \times V_{\text{VTEC}}] / V_{\text{VPS}}$. When TECCRT is used to control the TEC voltage directly, measure TECCRT to derive the TEC voltage instead, and use this formula: TEC voltage = $V_{\text{VPS}} - 2 \times V_{\text{TECCRT}}$. The maximum driving current of pin VTEC is 30mA and the output voltage swing is 0V to V_{VPS} .
7	CMIN	Analog input	Compensation input pin for the thermal control loop. Leave it open in production. When prototyping, use this pin with a tuner on the evaluation board, TECEV104 (produced by ATI) to tune the compensation network to match the characteristics of the thermal load.
8	TEMP	Analog output	Actual object temperature. It swings from 0V to V_{VPS} , corresponds to 15°C to 50°C when V_{VPS} equals to 5V. See the curve below.
9	SDNG	Digital input	Shut down control. When pulled low, it shuts down the controller. Leave it open or pull it high to activate the controller. The threshold voltage is 1.4V. This pin is internally pulled up by a resistor of 100k to VPS.
10	GND	ground	Signal ground, internally connected to Pin 4 GND. Can be used for connecting the thermistor



11	RTH	Analog input	Connect to the thermistor for sensing the desired object temp. Thermistor's other end connects to the signal ground, pin 4 or pin 10. Rth = 10kΩ @ 25°C. Other thermistors or temperature sensors can also be used, consult with us.
12	TECPOS	Analog power output	Connects to TEC positive terminal
13	TECNEG	Analog power output	Connects to TEC negative terminal
14	PGND	Power ground	Power ground for connecting to the power supply
15	PGND	Power ground	Power ground for connecting to the power supply, internally connected with pin 14
16	VPS	Power input	Positive power supply rail. The value is 5V.

Table 2. Characteristics (T_{ambient}=25°C)

Parameter	Test Condition	Value	Unit/Note
Object* temp. stability vs. ambient temp	V _{VPS} =5V, R _{LOAD} =0.8Ω	0.0002	°C/°C
Object temp. vs. set-point offset	T _{AMBIENT} is 0 ~ 50°C, set-point temp. is 15°C ~ 35°C	±0.1°C or ±15mV	
Object temp. response time	≤0.1 to the set-point temperature at a 1°C step	<5S	S
Efficiency	V _{VPS} =5V, R _{LOAD} =0.8Ω	≥90%	-
Max. output current	V _{VPS} =5V, R _{LOAD} =0.8Ω	6	A
Max. output voltage	V _{VPS} =5V, R _{LOAD} =0.8Ω	0 ~ (V _{VPS} -0.3)	V
PWM frequency		500	kHz
Power supply voltage	—	4.75 ~ 5.25 (specify 5V)	V
Set-point temp.** control voltage	V _{IN} =5V, R _{LOAD} =0.8Ω	0.1 ~ V _{VPS}	V
Default set-point temp. range***	V _{VPS} =3V	15 ~ 35	°C
Operating temp. range	V _{IN} =5V, R _{LOAD} =0.8Ω	-40 ~ 85	°C
Storage temp. range		-55 ~ 125	°C

* Object temperature refers to the actual cold side temperature of the TEC, on where the object is mounted.

** Set-point temperature is the temperature desired to have on the object.

*** Can be customized to any range according to requirement.

**** This TEC controller can only drive the TECs having > 1Ω impedance, which equals V_{MAX}/I_{MAX}.

***** After many experiment, according to the parameter and the figuring method of R_{load}, we advise customers to use R_{LOAD} of 0.8Ω. We advise customers to use voltage of 6V as the power supply.

BLOCK DIAGRAM

The block diagram of the controller is shown in Figure 3.

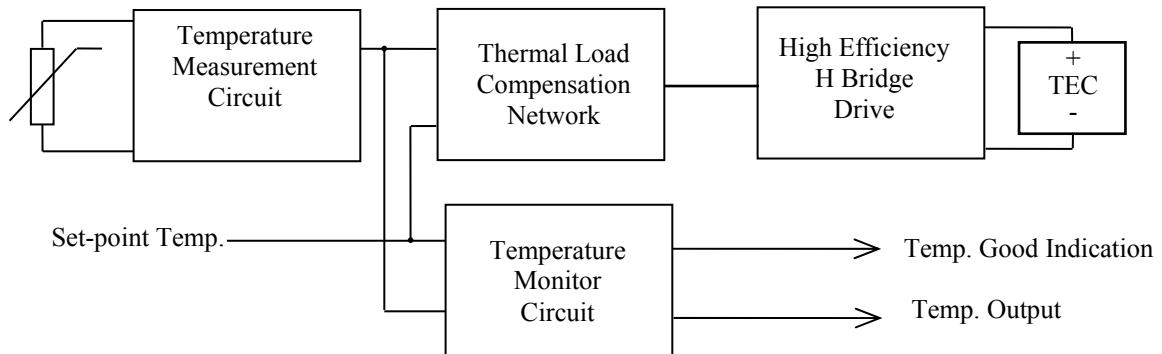

Figure 3. TEC Controller Block Diagram

APPLICATIONS

TEC controller connections are shown in Figure 4.

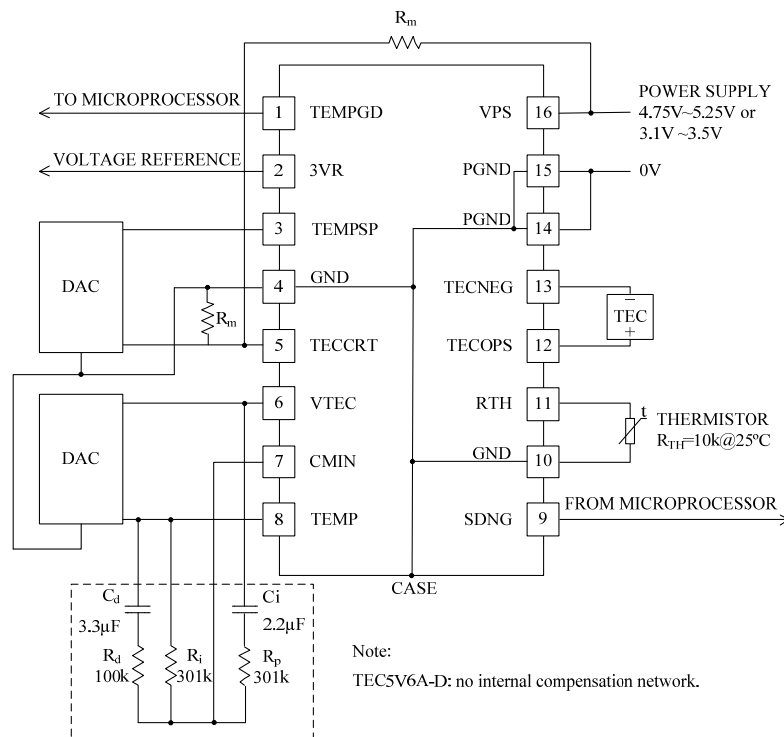

Figure 4. TEC Controller Connections

If you want to use this TEC controller for other applications not discussed here, such as use it with wave locker controllers, please consult us. The same as to other customizations, such as setting the TEMPSP by using a voltage source swings above 3V and/or V_{VPS} .

The TEC controller comes with a default temperature setting network, it sets the set-point temperature to be between 15°C to 35°C when setting the TEMPSP pin voltage to be between 0V to 3V linearly and using a specific de-facto “standard” 10k @ 25°C thermistor, with its R-T value data listed in Figure 8. When using different thermistors and/or needing different set-point temperature ranges, please contact us, we will configure the internal temperature network for you.

We recommend having the compensation network to be implemented by using the external components. For high volume applications, the compensation network can be implemented internally. The values of the components shown in Figure 4,



$R_d=100k\Omega/C_d= 3.3\mu F /R_i=301k\Omega/R_p= 301k\Omega /C_i= 2.2\mu F$, is just a set of values matching a particular thermal load. The users should tune the compensation network for matching their own thermal loads.

Note: This TEC controller doesn't come with an internal compensation network and we don't recommend using internal compensation network either. Implementing the network externally is highly recommended since it can be modified for driving different thermal load and/or the thermal load characteristics is not certain or fixed at the early design stage.

Using TEC Controllers for Driving A Heater

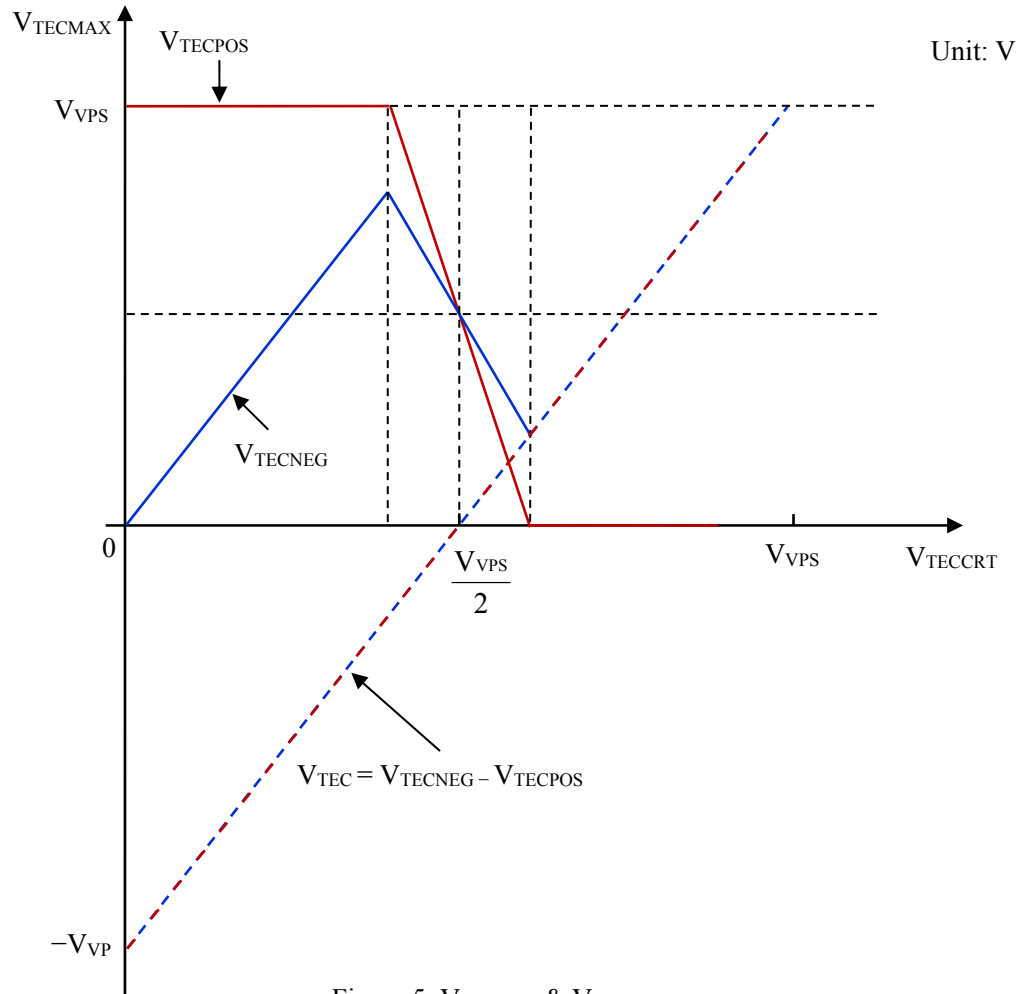

Figure 5. $V_{TEC\text{MAX}}$ & $V_{TEC\text{CRT}}$

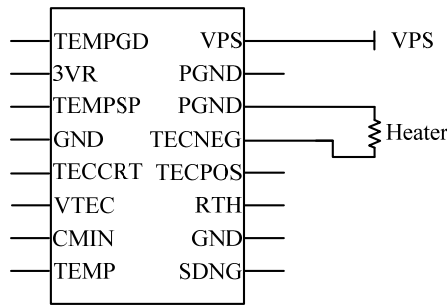

Figure 6.1 Driving A Heater Between 3.3V to 5.5V

If $6A \geq I_{HTMAX} \geq 4A$, use TEC5V6A-D.

If $4A \geq I_{HTMAX} \geq 3A$, use TEC5V4A-D.

If V_{HTMAX} is 3.3V, 5V, or between 3.3V~5.5V, use TECA1-5V-5V-D. $V_{VPS} = V_{HTMAX}$; $5.5V \geq V_{VPS} \geq 3.3V$; $I_{HTMAX} \leq 3A$.

Where V_{HTMAX} stands for the maximum voltage of the heater; I_{HTMAX} stands for the maximum current of the heater.

TYPICAL CHARACTERISTICS

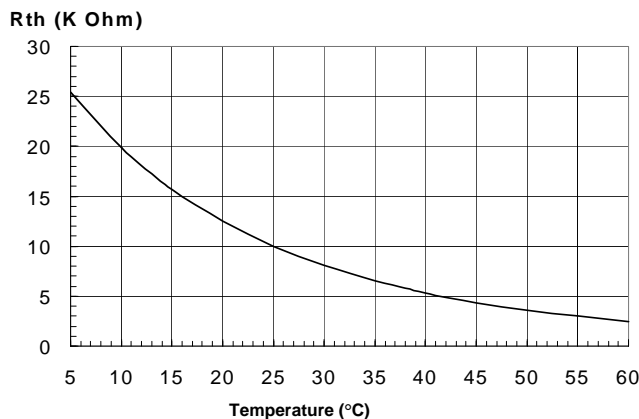

Figure 7. Rth vs. Temperature

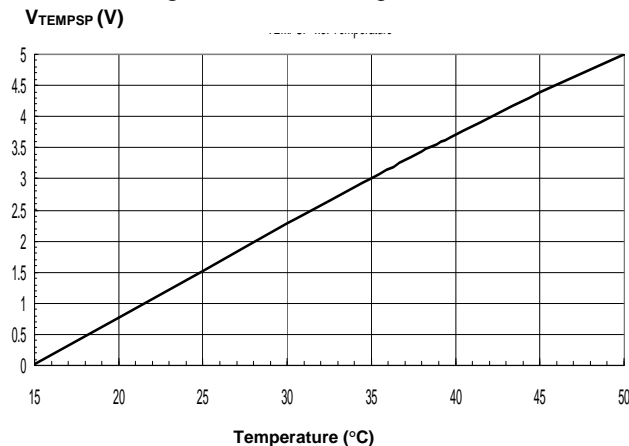

Figure 8. TEMPSP vs. Temperature

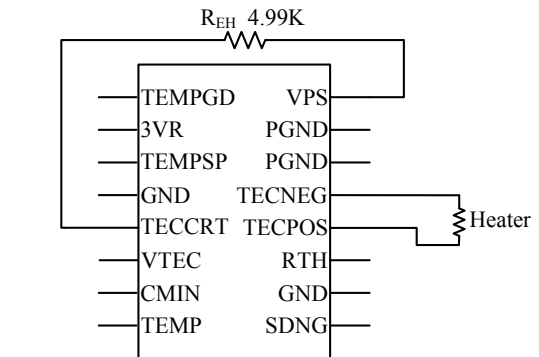

Figure 6.2. Driving A Heater for <3.3V @ $\leq 3A$

If $V_{HTMAX} < 3.3V$, the part # is TECA1-5V-[V_{HTMAX}]V-D. For example, $V_{HTMAX} = 2.5V$, the part number will become: TECA1-5V-2.5V-D, when using a 5V power supply. If powered by a 3.3V power supply, the part number will be: TECA1-3V-2.5V-D.

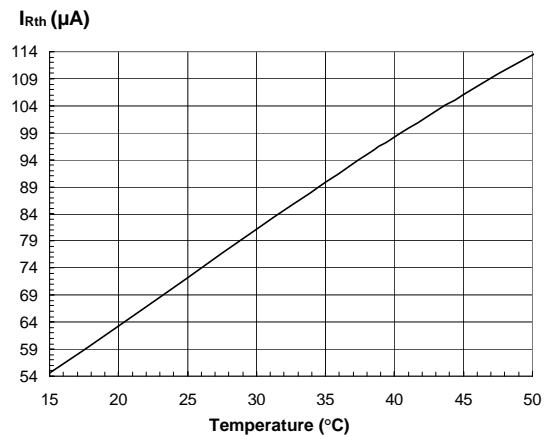

Figure 9. I_{Rth} vs. Temperature

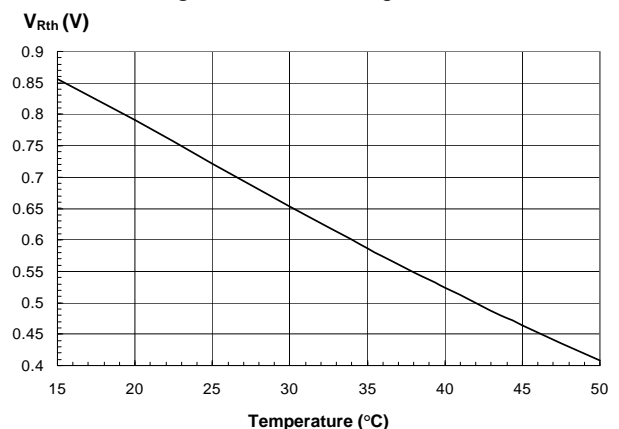

Figure 10. V_{Rth} vs. Temperature

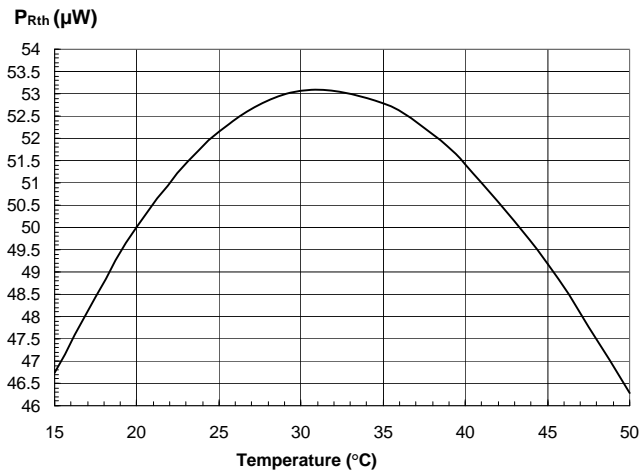

Figure 11. P_{Rth} vs. Temperature

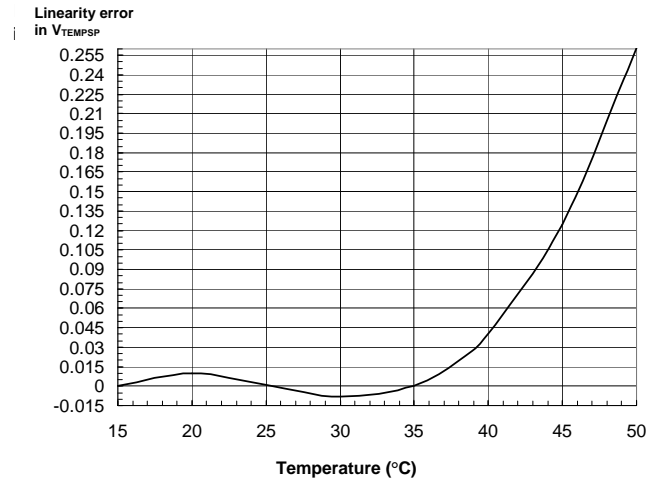

Figure 12. Linearity error in V_{TEMPSP} vs. Temperature

V_{TEC} & V_{TMO} WAVEFORMS

The V_{TEC} and V_{TMO} waveforms are shown in Figure 13, which change with V_{RTH}. We can see that there is no overshoot in the waveforms. V_{RTH} changes little, so there's no waveform shown. Figure 14 shows the connection method.

Compensation network: C_d=16.9uF, R_d=12.4k, R_i=1.872M, R_p=1.373M, C_i=1.69uF.

Note: Ch1: V_{TMO}; Ch2: V_{VTEC}

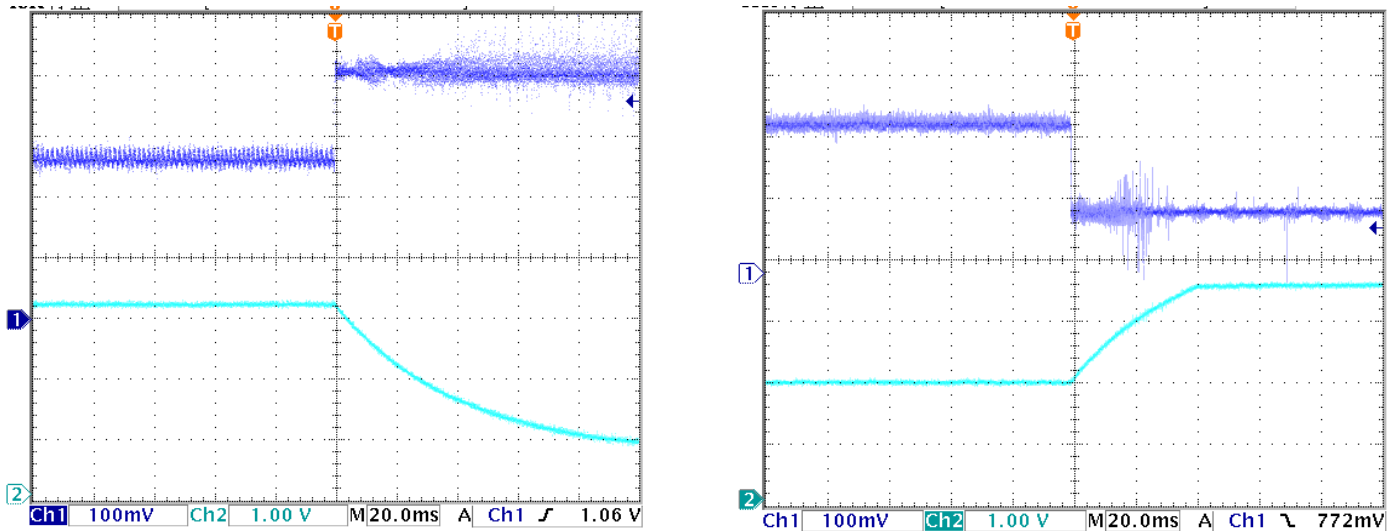

Figure 13. V_{TEC} & V_{TMO} Waveforms

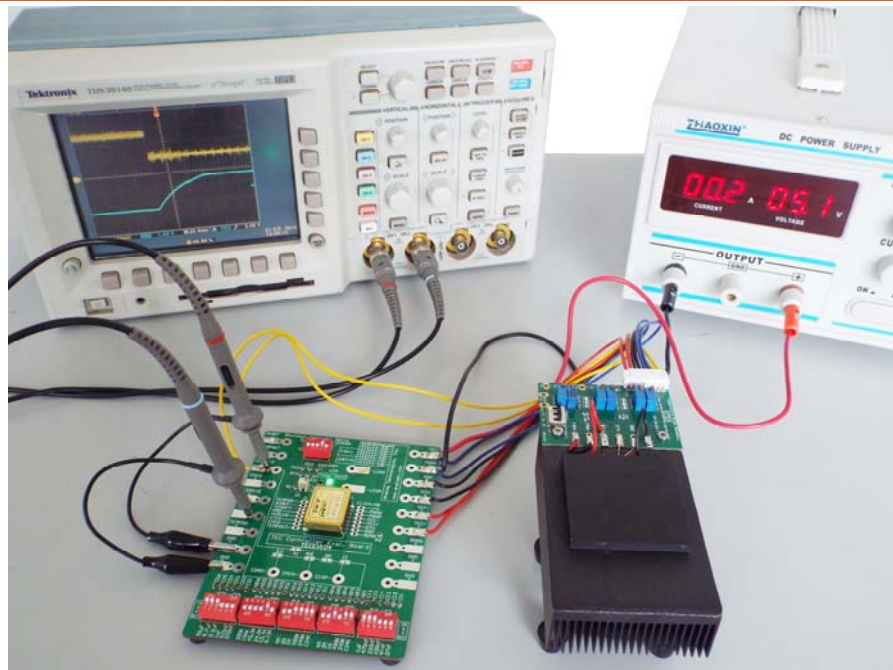

Figure 14. Connection Method

MECHANICAL DIMENSIONS

The controller comes in two packages: one is DIP or D package, and the other is SMT or S package. We have just introduced the DIP one in this doc., which comes with a part number: TEC5V6A-D, and you can also order the SMT one. Dimensions of the DIP package controller is shown in Figure 15.

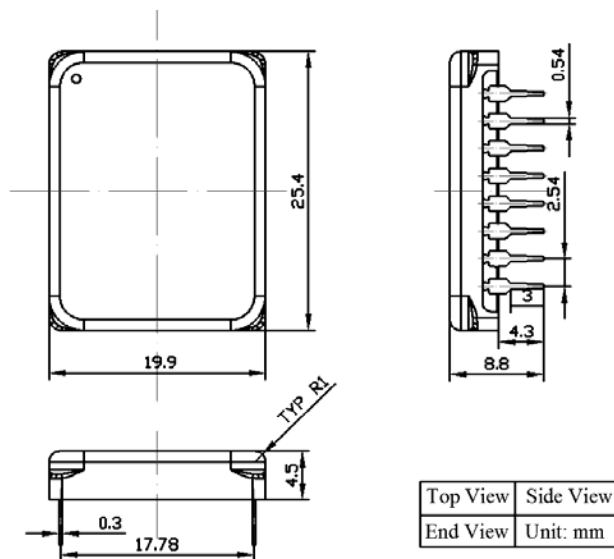

Figure 15. Dimensions of the DIP package controller of TEC5V6A-D

WARNING: Both the surface mount and the through hole types of modules can only be soldered manually on the board by a solder iron of < 310°C (590°F), they cannot go through a reflow oven process.



ORDERING INFO

We have two versions for this TEC controller, TEC5V6A-D, TEC5V6A-DA and TEC5V6A-DAH.

Table 3.

Part #	Description	Maximum $ V_{TEMP} - V_{TEMPSP} $ (mV)
TEC5V6A-D/S	TEMP=Off @SDNG=0	≤ 5
TEC5V6A-DA	TEMP=On @SDNG=0	≤ 5
TEC5V6A-DAH	TEMP=On @SDNG=0	≤ 0.5

Table 4. Unit Price

Quantity	1 - 9	10 - 49	50 - 199	200 - 499	≥ 500
TEC5V6A-D	\$86	\$83	\$80	\$77	\$73
TEC5V6A-S	\$86	\$83	\$80	\$77	\$73
TEC5V6A-DA	\$86	\$83	\$80	\$77	\$73
TEC5V6A-DAH	\$91	\$87	\$83	\$79	\$75

NOTE: The power supply may have overshoot, when happens, it may exceed the maximum allowed input voltage, 6V, of the controller and damage the controller permanently. To avoid this from happening, do the following:

1. Connect the controller solid well with the power supply before turning on the power.
2. Make sure that the power supply has sufficient output current. It is suggested that the power supply can supply 1.2 to 1.5 times the maximum current the controller requires.
3. When using a bench top power supply, set the current limit to >1.5 times higher than the maximum current the controller requires.

SPECIAL NOTE

If you experience a high current spike when you change TEMPSP voltage quickly by a large amount, such as $> 0.1V$, a capacitor of 1uF can be added between TECCRT and GND. For TEC controllers manufactured after Nov. 10, 2015, there is no such a problem.



NOTICE

1. ATI warrants performance of its products for one year to the specifications applicable at the time of sale, except for those being damaged by excessive abuse. Products found not meeting the specifications within one year from the date of sale can be exchanged free of charge.
2. ATI reserves the right to make changes to its products or to discontinue any product or service without notice, and advise customers to obtain the latest version of relevant information to verify, before placing orders, that information being relied on is current and complete.
3. All products are sold subject to the terms and conditions of sale supplied at the time of order acknowledgment, including those pertaining to warranty, patent infringement, and limitation of liability. Testing and other quality control techniques are utilized to the extent ATI deems necessary to support this warranty. Specific testing of all parameters of each device is not necessarily performed, except those mandated by government requirements.
4. Customers are responsible for their applications using ATI components. In order to minimize risks associated with the customers' applications, adequate design and operating safeguards must be provided by the customers to minimize inherent or procedural hazards. ATI assumes no liability for applications assistance or customer product design.
5. ATI does not warrant or represent that any license, either express or implied, is granted under any patent right, copyright, mask work right, or other intellectual property right of ATI covering or relating to any combination, machine, or process in which such products or services might be or are used. ATI's publication of information regarding any third party's products or services does not constitute ATI's approval, warranty or endorsement thereof.
6. IP (Intellectual Property) Ownership: ATI retains the ownership of full rights for special technologies and/or techniques embedded in its products, the designs for mechanics, optics, plus all modifications, improvements, and inventions made by ATI for its products and/or projects.